



**HAL**  
open science

## Modeling and simulation tool of a dual power energy system for hybrid vehicle design

K El Kadri, A. Berthon

► **To cite this version:**

K El Kadri, A. Berthon. Modeling and simulation tool of a dual power energy system for hybrid vehicle design. International Review of Electrical Engineering (I.R.E.E.), 2006, 1. hal-01997144

**HAL Id: hal-01997144**

**<https://hal.utc.fr/hal-01997144>**

Submitted on 17 Nov 2023

**HAL** is a multi-disciplinary open access archive for the deposit and dissemination of scientific research documents, whether they are published or not. The documents may come from teaching and research institutions in France or abroad, or from public or private research centers.

L'archive ouverte pluridisciplinaire **HAL**, est destinée au dépôt et à la diffusion de documents scientifiques de niveau recherche, publiés ou non, émanant des établissements d'enseignement et de recherche français ou étrangers, des laboratoires publics ou privés.

# Modeling and simulation tool of a dual power energy system for hybrid vehicle design.

K. El Kadri, A. Berthon,

**Abstract** – This paper proposes the study of a dual power energy system carried out for an experimental test bench ECCE (Evaluation of the Components of an Electric Power train) that is a hybrid series vehicle. This work will focus on the study of the various components (batteries, thermal engine, alternator, control), in order to make evolve this platform by testing several operating modes and also to determine the performance and operation limits. This work has been also carried out in order to achieve a simulation tool which will represent the operation of the hybrid energy system and which can be used to study for example the decayed mode, the availability of the sources of energy and the functionalities of the various parts of a hybrid vehicle. Further works are planned to integrate ultracapacitors energy storage and also fuel cell energy generation.

**Keywords:** series hybrid vehicle, block modelling, failure management, safety functionality, simulation tool, battery, energy management, converter control strategy

## I. Introduction

The aim of this paper is to propose a simulation tool in order to design a dual power generator for hybrid vehicles. This system presents some advantages like the redundancy and the energy availability. To explore this solution, modelling of the elementary components will be developed, simulation tool of the whole system will be implemented and experimental tests will be performed. However this study will focus on the power energy system applied to the hybrid vehicle.

Most of popular hybrid vehicles HEV, use gasoline and electric batteries associated to internal-combustion engines (ICE) and electric motors. This paper will present an experimental series hybrid vehicle (ECCE). The power system of this heavy vehicle consists on two generator units: the first unit (diesel ICE “MT1”+ alternator “AL1”) is of 80kW of power and it works at a constant speed and the second one (diesel ICE “MT2”+ alternator “AL2”) having 80kW of power works at a variable speed mode. Both units supply a DC bus for

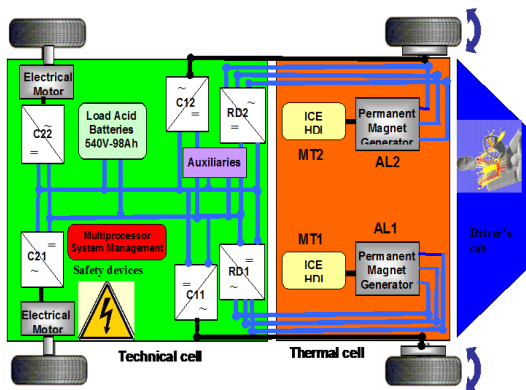

Fig. 1. Synoptic schema of the studied vehicle

which the voltage is fixed at 540V ( $\pm 270V$ ) by a pack of batteries (BAT1 and BAT2).

This 12 tons electric truck has four independent driving wheels (4x30kW) supplied by a DC bus, thanks to four inverters.

## II. Presentation of the power generation system

ECCE test bench has been developed to test in real conditions different technologies of energy sources, electrical loads and the modes of control and management of the embarked energy. The different components on board this vehicle test bench will be detailed below.



Fig. 2. The test bench ECCE.

### II.1. The two generator units

Two identical thermal engines (MT1 and MT2) drive respectively the two electrical generators (AL1 and AL2). The thermal engines are HDI, common rail diesel engines, manufactured by PSA Peugeot-Citroën™; they provide a power of 80 kW at 4000 RPM. AL1 is a permanent magnet generator at constant speed. AL2 is a double fed induction machine running at variable speed which is called “generalized generator”. Each generator can provide a nominal power output of 66 kW [1], [2].

AL1 and AL2 are connected, by their associated converters RD1 and RD2, to the DC bus at a rated voltage of 540 volt.

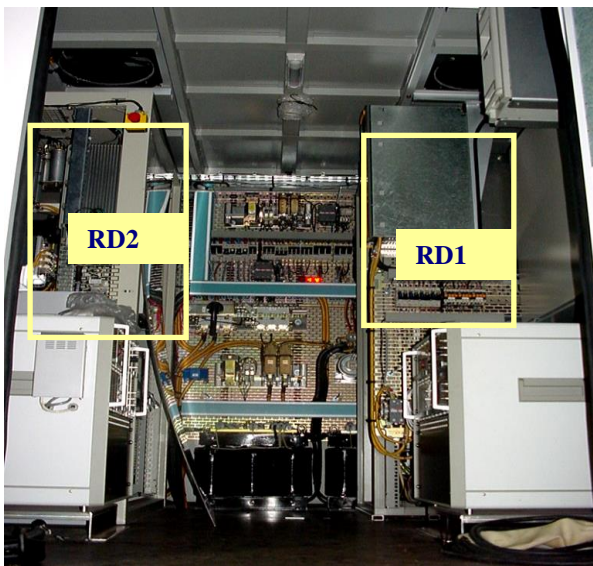

Fig. 3. The technical cell

### II.2. Batteries

The batteries are used to provide the energy during transient conditions and to store it during regenerative braking. Studied batteries are set with two subsets of 45 cells of 6 V mounted in series, that is to say two subsets of 270 V. These subsets are assembled in series on both sides of a middle point which is connected to the ground of the vehicle.

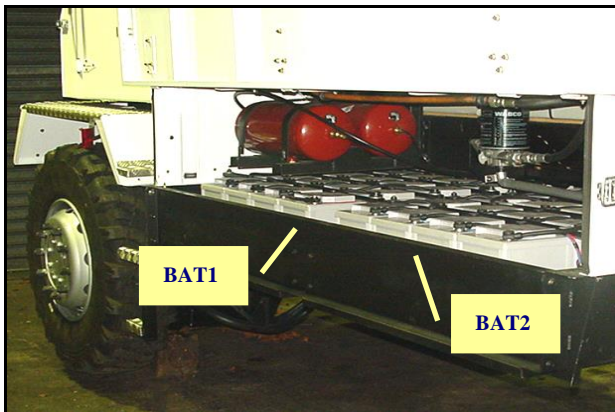

Fig. 4. The two packs of battery (BAT1 and BAT2)

### II.3. Control system

The control desk is based on a dSpace™ device which controls the power management, the ESP capability (Electronic Stability Program: virtual differential, anti-slipping, trajectory control), the data acquisition, the real time command-control and the diagnosis.

There are two units in the control desk: a dSpace™ device and a programmable logic device PLD which manages the step by step tasks of the elements of the bench.

## IV. Modeling and simulation of the hybrid vehicle

One interesting way to study the behavior of electrical vehicles is to develop a simulator tool in order to understand and design all their capabilities [3], [4]. In the context of vehicle computer aided design, models are needed for the simulation of the power train system and auxiliaries [5], [6], [7], [8]. To achieve this goal, numerical models of the power system will be proposed, using SABER software. This software might also simulate the different problems encountered in series hybrid vehicle. Furthermore, it allows getting the time variations of currents and voltages in the different circuits following normalised drive cycle.

The first step before simulation is modeling. In this step elementary modules have to be defined in order to achieve, by assembling the modular devices, the simulation of the behavior of various vehicles: conventional, electrical or hybrid ones.

To simulate the vehicle, the system has been divided in several blocks, which will be detailed now.

### IV.1. The power energy system

Several studies focus on research and evaluation on different approaches to model Diesel engine. The proposed models are fitted to the dynamic relationship between indicated pressure, torque and speed of the engine [9]. In this application a model is needed with information on the fuel consumption depending on a speed set point and a rotational velocity type terminal.

The model of the thermal engine is connected to a system with three terminals:

- engine\_vel\_cons - control type connection pin which is expected to be connected to the profile of the velocity.
- eng\_idle\_rpm - control type connection pin which is expected to be connected to the engine idle speed control unit.
- eng\_shaft - rotational velocity type terminal which corresponds to an engine power take off shaft. The terminal is associated with the angular velocity in rad/s as the across variable and the torque in Nm as the through variable. An alternator can be connected to this terminal.

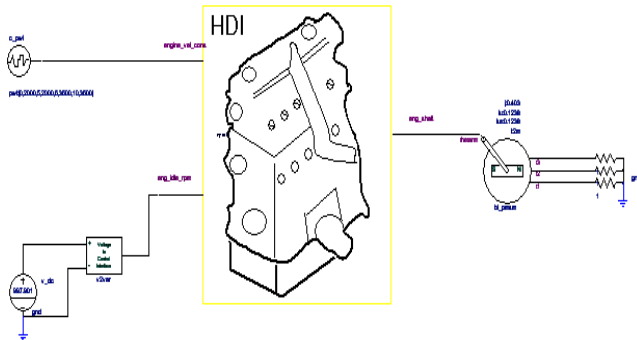

Fig. 5. The HDI thermal engine model.

Fuel consumption is modelled as a 3-D look-up table data, which defines the fuel flow (litres/min or gallons/min) versus engine torque and engine velocity (RPM), or fuel flow versus engine mechanical power and engine velocity (RPM).

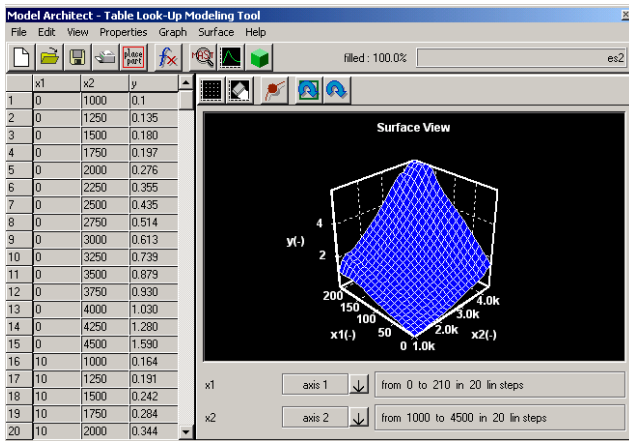

Fig. 6. The 3-D look-up table.

The data provided must adequately cover the region of operation. Experimental or measured data are often clustered about specific regions of operation.

The two 66 kW alternators (AL1 and AL2) are connected to the diesel engines MT1 and MT2.

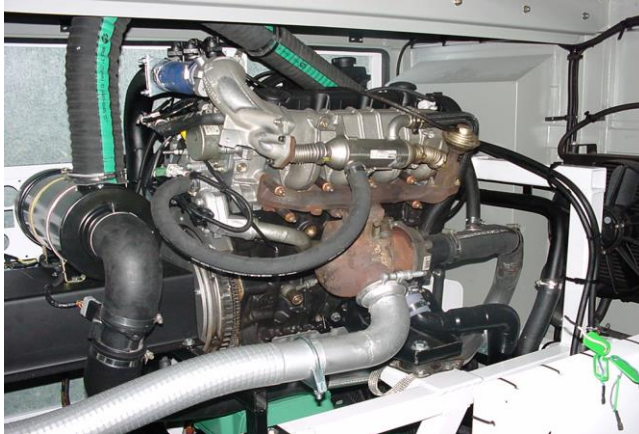

Fig 7. The HDI diesel engine.

The two alternators (AL1 and AL2) are from two different types: AL1 is a permanent magnet generator at constant speed and AL2 is a double fed induction

machine which acts as a “generalized generator”.

Our block model represents a permanent magnet synchronous machine with angular velocity of the shaft as the mechanical connection point. Both the back emf and torque produced by this machine are modelled, based on an approximation using the first nine harmonics of the magnetic fields. Machine parameters include the resistance and inductance of the three phase windings. Torque and back emf multiplying constants as well as the coefficients of the first nine field harmonics are parameters of this model. Internal damping and inertia of the unloaded machine as well as the number of machine poles are additional parameters.

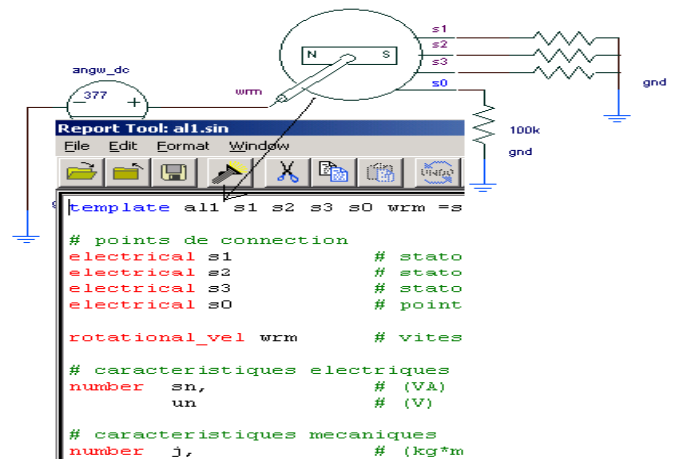

Fig. 8 AL1 alternator model.

The phase voltage and the angular velocity are presented as shown by (1):

$$v_k(t) = R_s \cdot i_k(t) + L \frac{di_k(t)}{dt} + e_k(t)$$

$$e_k = \sum_{i=1}^9 a_i \cdot \sin(i \cdot (\theta_{elec} + \varphi)) \times k_e \times p \times \Omega \quad (1)$$

$$= E_k \times k_e \times p \times \Omega$$

$$\Omega = \frac{d}{dt} \theta_m$$

Where  $R_s$ ,  $L$ ,  $k_e$  and  $p$  designate respectively the stator resistance, the stator inductance, the emf constant and the number of poles per phase.  $i_k$ ,  $e_k$ ,  $a_i$  and  $\theta_m$  respectively represent the current, the emf, the coefficients of field harmonics and the angular position.

The schema of the generator AL2 is given on figure 9 and its nominal values are given below. It can be observed that for a speed lower than 2700 rpm which is the synchronous speed for a frequency of 90 Hz, the power needed for the converter is taken on the DC bus bar.

- poles : 4 ;
- rated power : 66 kW ;
- rated voltage : 430 V at 3600 rpm ;
- rated current : 82 A



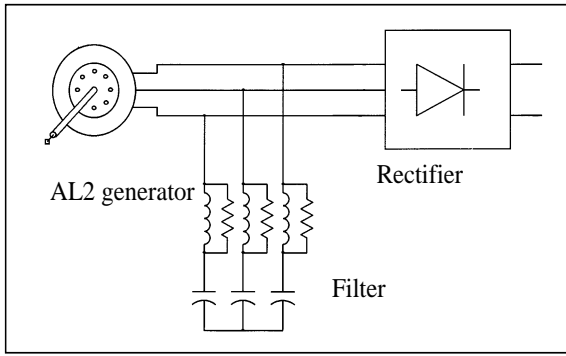

Fig. 9 AL2 alternator.

The vector equations describing the alternator are,

$$\begin{aligned} \underline{V}_s &= R_s \cdot \underline{I}_s + \frac{d\Phi_s}{dt} \\ \underline{V}_r &= R_r \cdot \underline{I}_r + \frac{d\Phi_r}{dt} \\ \Phi_s &= L_s \cdot \underline{I}_s + X_m \cdot \underline{I}_r \\ \Phi_r &= L_r \cdot \underline{I}_r + X_m \cdot \underline{I}_s \end{aligned} \quad (2)$$

Applying Park's transformation:

$$\begin{aligned} I_{sd} &= \cos \theta_{elec} * I_{s1} + \cos(\theta_{elec} - \frac{2\pi}{3}) * I_{s2} + \cos(\theta_{elec} - \frac{4\pi}{3}) * I_{s3} \\ I_{sq} &= -\sin \theta_{elec} * I_{s1} - \sin(\theta_{elec} - \frac{2\pi}{3}) * I_{s2} - \sin(\theta_{elec} - \frac{4\pi}{3}) * I_{s3} \\ I_{r1} &= \frac{2}{3} * [\cos \theta_{elec} * I_{rd} + \cos(\theta_{elec} + \frac{\pi}{2}) * I_{rq}] \\ I_{r2} &= \frac{2}{3} * [\cos(\theta_{elec} - \frac{2\pi}{3}) * I_{rd} + \cos(\theta_{elec} - \frac{2\pi}{3} + \frac{\pi}{2}) * I_{rq}] \\ I_{r3} &= \frac{2}{3} * [\cos(\theta_{elec} + \frac{2\pi}{3}) * I_{rd} + \cos(\theta_{elec} + \frac{2\pi}{3} + \frac{\pi}{2}) * I_{rq}] \end{aligned} \quad (3)$$

The system of flux can be written by:

$$\begin{aligned} \Phi_{sd} &= L_s \cdot I_{sd} + X_m \cdot I_{rd} \\ \Phi_{sq} &= L_s \cdot I_{sq} + X_m \cdot I_{rq} \\ \Phi_{rd} &= L_r \cdot I_{rd} + X_m \cdot I_{sd} \\ \Phi_{rq} &= L_r \cdot I_{rq} + X_m \cdot I_{sq} \end{aligned} \quad (4)$$

Where  $I_{sd}$  and  $I_{rd}$  are the direct currents (stator and rotor) and  $I_{sq}$  and  $I_{rq}$  are the quadrature currents (stator and rotor).  $L_s$ ,  $L_r$  and  $X_m$  respectively represent the stator and rotor cyclic inductance and the mutual inductance.

$I_{s1}$ ,  $I_{s2}$  and  $I_{s3}$  designate the stator phase currents and  $I_{r1}$ ,  $I_{r2}$  and  $I_{r3}$  the rotor phase currents.

The AL2 generator is controlled by one converter which feeds the rotor of the generalized generator.

AL1 and AL2 are connected by their respectively converters RD1 and RD2, to a DC busbar at a rated voltage of 540 volt.

For RD1 converter, the output of the DC current  $I_{rd1}$  regulator will be the quadrature current reference,  $i_{q\_ref}$ . In this study, for a considered positive rotor speed,  $i_{q\_ref}$  is imposed at a negative value. The direct reference current  $i_{d\_ref}$  is fixed to zero in order to minimize the copper losses for a given load power. So, the phase current and the corresponding phase emf have  $180^\circ$  phase shift. The phase reference currents  $I_{11\_ref}$ ,  $I_{12\_ref}$  and  $I_{13\_ref}$  are obtained by applying Park's transformation to the dq current references. The resulting currents will be compared to the phase currents feedback  $i_{11}$ ,  $i_{12}$  and  $i_{13}$  in the hysteretic current controllers. The outputs of this hysteretic controller will be the driving signals for the rectifier transistors. [10]

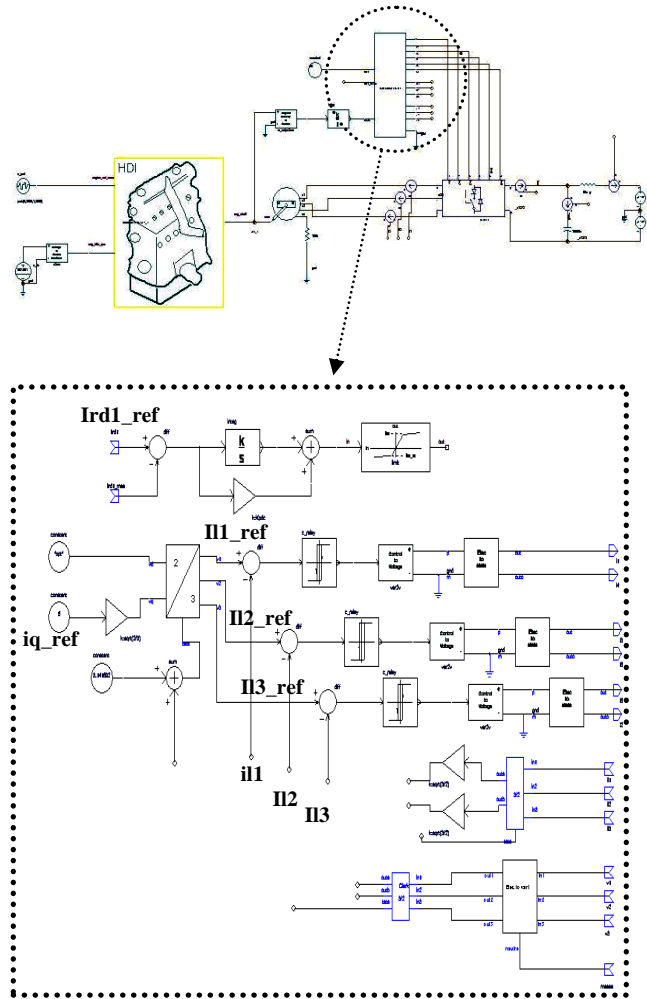

Fig. 10. RD1 inverter model.

For RD2 converter, the output of the DC current  $I_{rd2}$  regulator will be the quadrature voltage reference,  $V_{qs}$  ref. In this case the use of PWM converter is adopted to supply the rotor of the AL2 generator.

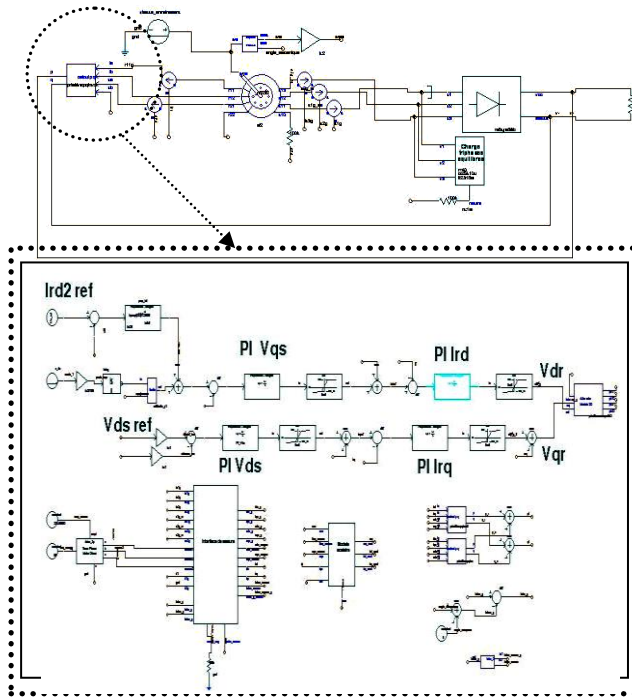

Fig. 11. RD2 inverter model.

For this simulation, currents and voltages space vector representations are used to obtain system equations.

#### IV.2. Battery modeling

As batteries represent a fundamental and central element in the hybrid vehicle, it is necessary to study some electric modeling of these batteries.

There are so numerous models for batteries, from impedance and voltage source in series modeling to more complex models. Generally, these models consist on an equivalent electric circuit made up of resistors, capacitors and other elements, fixed or variable elements, depending on the temperature and the state of charge SOC which gives an idea on the quantity of active part [11]. These models are used to determine the state of charge or to evaluate the lifespan of the batteries [12], [13].

The principal models available in the literature are:

- Simple electric model
- Dynamical model [14]
- The third-order battery model [15]
- Mathematical Model [16]
- Parallel model [17]

The temperature is a very important parameter which has a great influence on the battery operation.

It affects:

- The electrochemical behavior of the system
- Efficiency of the state of charge and discharge
- Power and energy of the battery

- Safety and reliability of the battery
- Lifespan of the battery.

Thus, as the temperature affects the battery, this parameter influences also the performance of the hybrid vehicle, its reliability as well as the availability of energy on board.

In this simulation, in order to model the batteries of the vehicle ECCE, the third-order battery model has been chosen like the thermal model, because it has several advantages:

- all its components depend on the state of charge and the temperature which is a very important factor that cannot be neglected in the behavior of the lead acid batteries
- the easy way to identify the various circuit parameters.

The third-order battery model as shown on fig. 12 consists on:

- an electric circuit containing a R/C cell in series with a resistance and an algebraic parasitic branch.
- algorithms to calculate the state of charge SOC and the internal temperature of the battery.
- equations to calculate the elements of the circuit according to the SOC and the temperature.

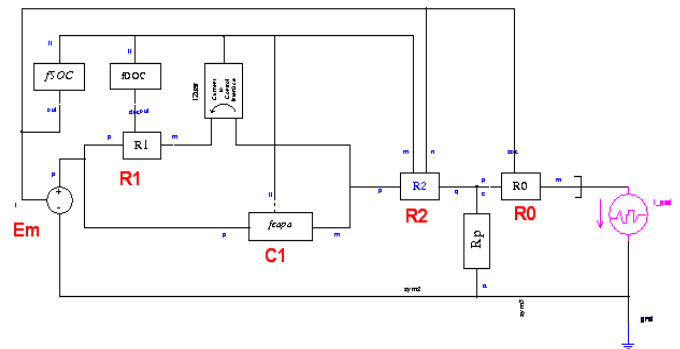

Fig. 12. Battery model.

All the components shown on figure 12 are function of the SOC, charge and discharge currents and of course of the temperature.

One can be expressed  $E_m, R_0, R_1, R_2$  by:

$$E_m = E_{m0} - K_E (273 + \theta)(1 - SOC)$$

$$R_0 = R_{00}[1 + A_0(1 - SOC)] \quad (5)$$

$$R_1 = -R_{10} \ln(DOC) \longleftrightarrow R_1 * C_1 = \tau_1$$

$$R_2 = R_{20} \frac{\exp[A_{21}(1 - SOC)]}{1 + \exp(A_{22}I_m / I^*)}$$

And the following relation (6) for the capacitor

$$C(I, \theta)_{I, \theta = const} = \frac{K_c C_0^*}{1 + (K_c - 1)(I / I^*)^\delta} \left(1 + \frac{\theta}{-\theta_f}\right)^\varepsilon \quad (6)$$

All these parameters can be identified easily using the experimental tests. A constant current discharge can be made fixing the temperature by putting the battery in a climatic room, and measurements of the voltage from its terminals are carried out.

Battery parameters referring to the model are determined from several experimental tests and are shown on Table II.

Table II  
PARAMETERS REFERRING TO THE MODEL OF ONE BATTERY ELEMENT

<b>Capacity parameters</b>	$I^*$ : 19.62A	$\theta_f$ : -40°C
	$C_{0*}$ : 18.12Ah	$K_c$ : 1.5097
	$\epsilon$ : 1.2274	$\delta$ : 0.9803
<b>Em</b>	$Em_0$ : 2.2279V $K_E$ : 0.6544mV/°C	
<b>R0</b>	$R_{00}$ : 8.40 mΩ	$A_0$ : -0.152063
<b>R1-C1</b>	$R_{10}$ : 4.35 mΩ	$T_1$ : 910 s

The following curves show the experimental and simulation behavior:

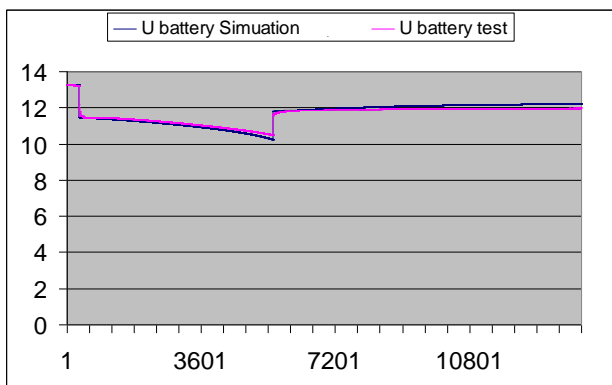

Fig. 13. Simulation and test results for battery voltage during 20A constant current discharge at 20°C.

Several other tests using various temperature and currents give the different parameters of the previous relations.

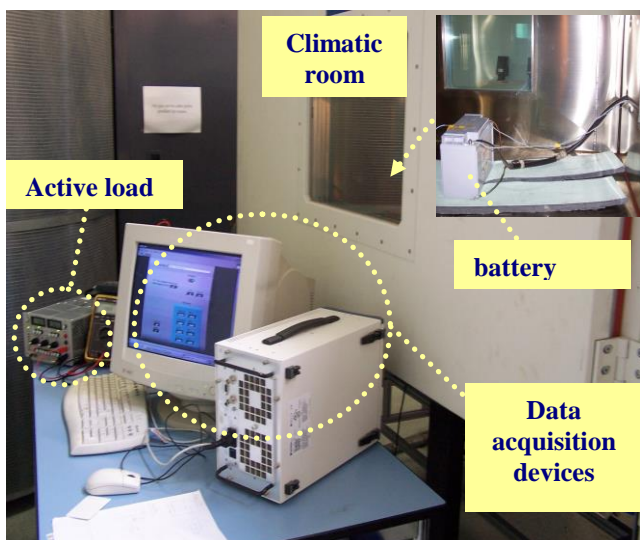

Fig. 14. Battery test laboratory.

## V. Simulation results

Simulation results will be presented for the ECCE vehicle. Figure 15 shows the implementation of the whole system modeling.

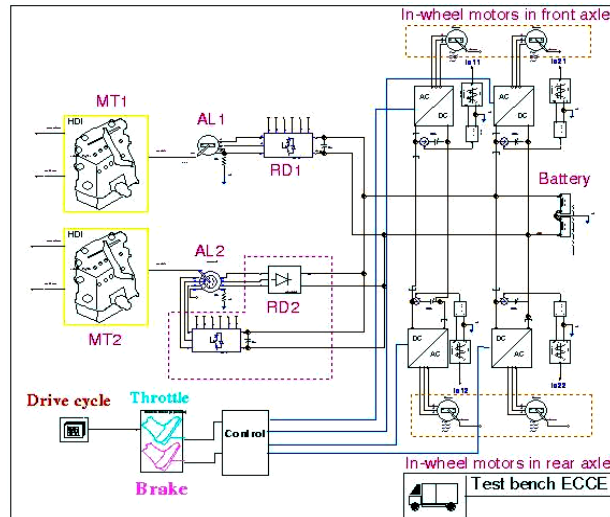

Fig. 15. Simulation synopsis.

This study permits to have an idea on the general behaviour of the test bench ECCE and also of the components which are requested among the energy sources and the main energy consumers.

Possible problems related to the quality of the waveforms can occur, in particular with regards to the load current of the battery.

For the ICE the following figures will present fuel consumption and axle torque for a speed reference varying from the standby position to nominal speed at 3600rpm.

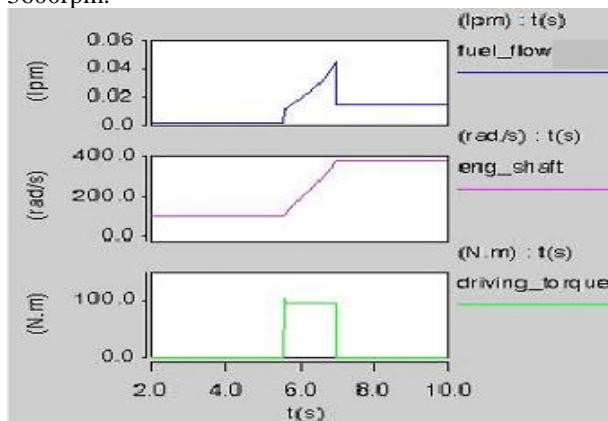

Fig. 16. Simulation results for the ICE thermal engine.

For power request from AL1 electric generator, figure 17 shows some results with a DC bus current regulated to 50A ( $I_{rd1\_ref}=50A$ ). These results validate the driving control of the generator MT1-AL1-RD1.

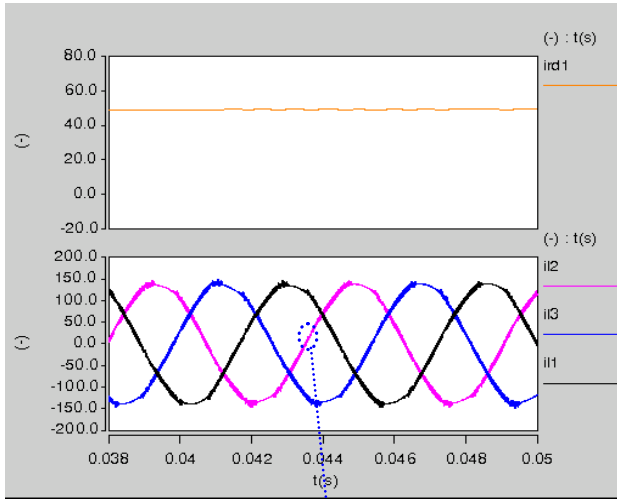

Fig. 17.a. Ird1 current at the output of RD1 and stator current for AL1

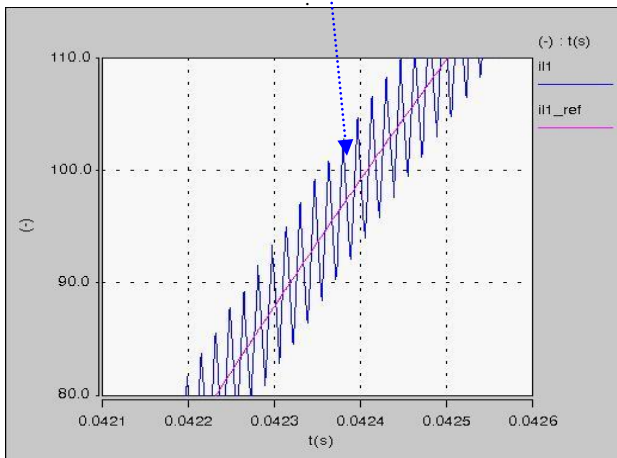

Fig. 17.b. Stator current for one phase for AL1.

Figure 17.c. shows the hysteretic control of the current issued from the rectifier RD1.

For power request from AL2 electric generator, figure 18 and 19 shows some results with a DC bus current regulated to 50A ( $I_{rd2\_ref}=50A$ ). These results validate the driving control of the generator MT2-AL2-RD2.

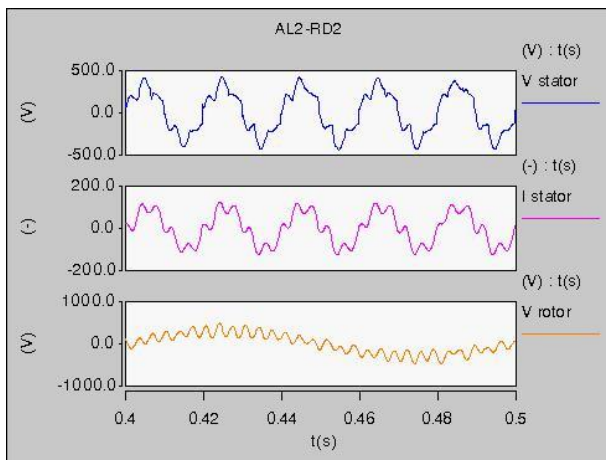

Fig. 18. The stator phase voltage and current and the rotor voltage of the AL2 alternator.

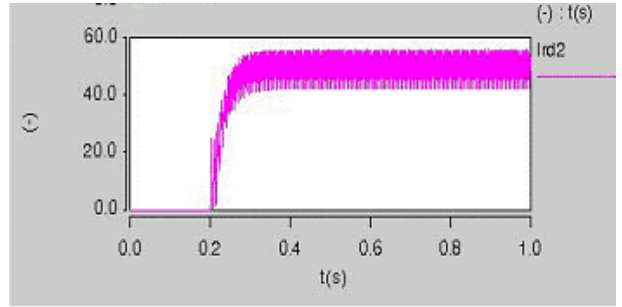

Fig. 19. Ird2 current at the output of RD2 and power supply from AL2.

To validate this simulation the related experimental results are presented in the following figure:

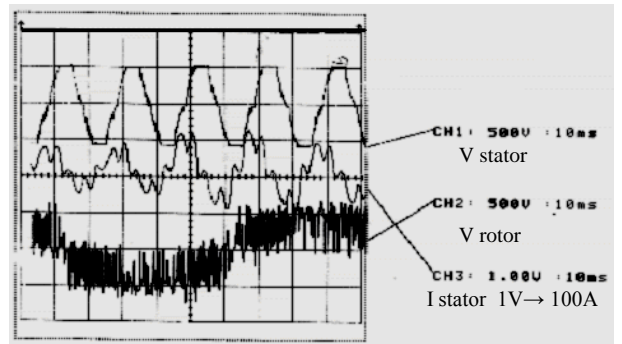

Fig. 20. Experimental results for AL2.

For power request from electric generators figure 21 shows some results with a DC bus current regulated to 50A ( $I_{rd1\_ref}=50A$ ) for a power traction demand "itraction".

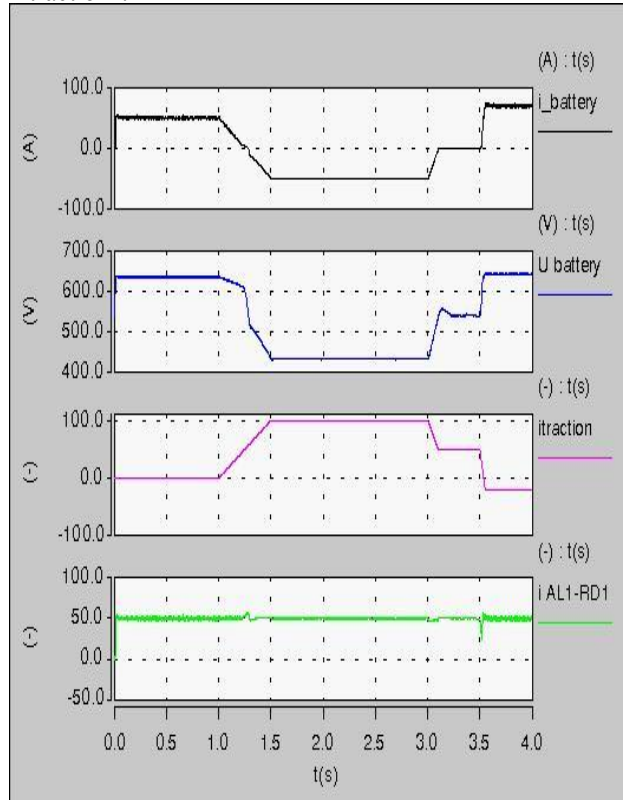

Fig. 21. Results for a simulation for "itraction" demand.



## V. Real system and tests

Concerning the design of the test bench, some safe practice has to be considered. In fact, as human users will take place on board, safety rules are required and will be developed below.

The term of "safety" in the classical vehicles is strongly related to the safety of the passengers in a context of traffic regulations (seat belt, airbag...). With the emergence of the electric and hybrid vehicles, several institutes have been interested in the last years to the new concept of safety in the electrical vehicle. This new concept has a lot of specificities regarding to the classical ones because of the great number of the embedded electrical engineering components: sources of energy, energy storage elements, power converters, motors, regulations devices... etc.

This presented study is intended to underline the risks taken by the personnel using a DC voltage higher than 60V. The studied electrical vehicle (the EV "ECCE", fig. 1) has a DC bus of 540V obtained through two packs of batteries at 270V for each. First, a state of art on the electric risks will be reminded, especially the different approaches of the standards in electricity talking about the use of the DC voltage around 540 V. The standards dedicated to the protection in the electric vehicle and the embarked systems are more explained.

Afterwards, a simulation strategy will be presented to manage failures on a heavy series hybrid vehicle. Safety functionality have been considered and implemented in a control algorithm in order to keep the entire drive control of the vehicle. Full experimental and simulation results (with modeling description of the devices) will be detailed.

The 540V DC bus is sufficiently high to be regarded as hazardous for people; its use requires an absolute safety of operation. It is thus necessary to set up measurements and safety devices in order to make it possible, on the one hand to guard itself against the electric shocks, and on the other hand to protect the electrical installation [18].

### III.1. The standards

The installations and the electric materials are subjected to a whole of texts having as main purpose to ensure the protection of the equipments and the people. This safety implies the use of equipment meeting standards of construction and defining the rules of installation of these devices. In the same way, preventive actions must be respected to avoid any electric shock or failure in the electric circuit.

Three levels are concerned with the starting of these actions of standardization: national (AFNOR and UTE in France), European (CEN and CENELEC) and international (ISO and CEI).

The consultation of these various organizations brings back to us to some normative texts about the

electric vehicle and the use of the DC voltage in the electric traction.

In reference of these standards, some proposals ensuring the protection of persons and equipment have been applied on ECCE vehicle.

### III.2. Analysis of risks related to the use of 540V DC voltage

The effects of currents passing through the human body are same, that they act of direct contact or of indirect contact, as from the moment when the potential difference between the exit and entrance points, as well as the duration of current crossing, are identical. The analysis of the accidents due to electric shock resulted is classified in two categories according their origin.

The hazards incurred by the people crossed by an electrical current depend primarily on its intensity and the time of crossing. This current is directly related to the voltage of the contact applied to this person, as well as impedance met by this current at the time of its advance through human body (characteristic physiological being human concerned), the voltage of the contact and the humidity of the skin.

In the case of the D.C. current, it can occur, because of the presence of salts and liquids in the body, of the electrolytic effects with the same way to involve electrochemical reactions. Nevertheless, with the same voltage level, the AC current 50-60 Hz is more dangerous than the D.C. current. According to document CEI 479-1, the report/ratio of a forward current to its equivalent effective value of AC current having the same probability of producing a ventricular fibrillation is as follows:

$$K = \frac{I_{cc \text{ fibrillation}}}{I_{ca \text{ fibrillation}}} = \frac{300mA}{80mA} = 3.75 \quad (7)$$

### III.3. Protection of persons against electric hazards

#### 1) Protection against the direct contact:

According to the European standard and French NF EN 1987-3 approved in February 1998, protection against the direct contact must be made up by the following way:

- By insulation: The live parts of the electric system must, by assembly of the vehicle be completely covered by the insulation (basic, additional or reinforced) which can be removed only at the price of its destruction.
- By partitions or enclosures.

It is the first solution which will be adopted in our case. These two actions prescribed by the standards are primarily "preventive" or "passive" measures, i.e. the "setting out of reach" live parts.

The decree of application of section IV of the decree, by the reference with the article of standard NF C15-

100, advises the use by way of complementary protection, a high sensitivity differential circuit breaker (DDRHS) of lower value or equalizes with 30mA. This constitutes a protection measure known as "active", since it puts in work the operation of a shutting-off device at the moment when the current runs out with the ground while crossing the body of a person in contact with a stripped active driver. In our case the use of a differential device will not be possible owing to the fact that the continuous network is not isolated from the ground. The point medium of the battery is connected to the frame of the vehicle which is the so called ground. On the other hand we produced a model of detection of insulation defect. The later will be placed in the frame of the vehicle.

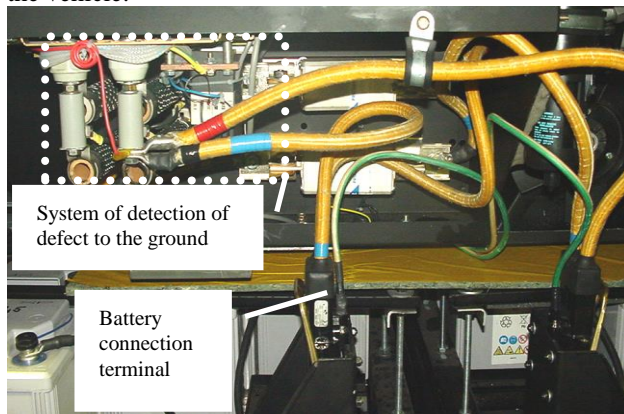

Fig. 22. Safety means and protection against failures.

## 2) Protection against the indirect contact:

The people must be protected from all the risks resulting from the contacts with accessible conducting parts (exposed-conductive-parts) in the event of failure from the electric circuits of the vehicle. These electric grounds should not be confused with the electronic ground suitable for the operation of the electronic sets. They are connected to the ground through a protective conductor.

In this class of voltage level, this protection is obtained by protective bonding. In electrical equipment, electrical connection of exposed-conductive-parts and/or protective screening to provide electrical continuity to the means of connection for an external protective conductor.

### III.4. Functional safety means

The goal of this part is to establish a new concept of safety in order to avoid the dangerous consequences of the failures affecting the people and components specific to the hybrid vehicles (the other components are considered in the same manner as in the case of the traditional vehicles).

This concept of safety includes actions and principles of design having to be adopted in order to guarantee a sufficient protection against the physical and material damages in case of failures [19].

Several instructions have to be respected in the starting of the vehicle: control, driving, forward or backward, parking. These tasks are made among these instructions:

- The starting is done by means of the ignition key, which counts two positions at least:

Position 1: "Stop": The system of propulsion is disconnected; an action on the accelerator pedal is without effect. This position is the only one which makes it possible to insert and to withdraw the ignition key.

Position 2: "Drive": An action on the accelerator pedal after at least another voluntary action makes it possible the vehicle to move.

- If the power of drive is reduced to a significant degree by the action of an automatic device (because of a high temperature of the propulsion system or components of the energy sources, for example), this phenomenon must be taken into account in the total management of the system.

- Also, the low level of the state of charge (SOC) of the battery pack also constitutes another parameter which influences the management of the vehicle. The value of the SOC level of the battery must be made according to the 'laws' of energy management, but must in any case satisfy particular requirements of safety.

The control of the vehicle is assured by the driver installed in the cab of vehicle (figure 23.a and figure 23.b):



Fig. 23.a. Cockpit.



Fig. 23.b. Instrument panel

In order to validate the correct working of all the subsets, we initially chose to force the operation of the two power generating units according to the power requested on the DC bus. However the choice of the control strategy does not take into account the points of ideal efficiency of the generators neither the losses.

So, it can be seen that the computer tools could propose several ways to analyse the dependency of some elements of the power train to electrical or thermal constraints resulting from a safety drive of the vehicle from the point of view of electrical energy management. Accurate models have been developed for this simulator and validations have been made for the most part of the elements. However, a normalized driving profile has to be submitted to validate the dynamical behaviour of the system [20]. Up to now, only some behavioural tests have been performed because of the availability of the experimental ECCE truck.

For example, thanks to the dSpace system embarked, it is possible to record all the measured parameters. The data are then transmitted to a laptop connected to the calculator by Ethernet connection.

The initial voltage of the battery is 432V (540V-20%), we can observe the charge of the battery. The measured data are as follows:

- Position of the accelerator pedal (Ped ACC ranging between 0 and 1)
- Currents provided by generators (IRD1, IRD2)
- Battery voltage (UBAT)
- Battery current (IBAT). A current output by the battery is counted positively.

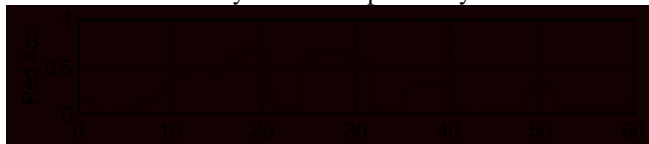

s



s

Fig. 24. Load current and battery voltage.

One can notice that the battery provides the complement of requested current.

## VI. CONCLUSION

Legal regulations on fuel consumption and the rising

need of comfort and safety are the main issues in automotive development.

The simulation tool for the dual hybrid generator experimental vehicle ECCE is especially important since one can efficiently test new components and control strategies. The interaction with other subsystems in a vehicle can be analyzed. Moreover, this simulator can be used with relatively fine models in order to start studied in case of default behaviour mode. Some defects could be proposed, for example an increase of the temperature of the batteries, or a failure in the converter, and the impact of such a failure on the performances of the entire system would be underlined. This study makes also it possible to see the availability of energy on board of the vehicle.

Moreover, the study carried out, is intended to make known the risks covered by persons working with DC voltage higher than 60V in particular in our paper with a 540V supply. This voltage is enough high to regard it as dangerous for the people. Electric analysis of risks was thus essential to avoid the personal injuries during interventions undertaken at the time of control or test procedures, or during maintenance periods.

## ACKNOWLEDGMENTS

This work was supported in part by the Electrical Engineering and Systems Laboratory – EA 3898. This project has been supported by French government DGA, ALSTOM, SNAA, and public laboratories INRETS and GREEN.

## REFERENCES

- [1] K. El kadri, D. Bouquain, D. Diop, R. Pusca, Y. Ait-Amirat, A. Berthon, J. M. Kauffmann, Test Hybrid Vehicle Management: Energy and Piloting, *AECV2002*.
- [2] K. El Kadri, A. Djerdir, A. Berthon, Simulation and design of a hybrid vehicle: failure and safety management, *PELINCEC*, October 2005.
- [3] Johanna Wall, *Modelling of Components for Conventional Car and Hybrid Electric Vehicle in Modelica Master's thesis performed in Vehicular Systems*, 10th May 2004.
- [4] Gerhard Schmitz (editor), M. Rubio, A. Urquia, L. González, D. Guinea, S. Dormido UNED and CSIC, Madrid, Spain Proceedings of the 4th *International Modelica Conference*, Hamburg, March 7-8, 2005.
- [5] Peter Fritzson, Principles of Object-Oriented Modeling and Simulation with Modelica 2.1.
- [6] Modelica Association, - A Unified Object-Oriented Language for Physical Systems Modeling, Version 1.4, December 15, 2000.
- [7] W. Lhomme1, A. Bouscayroll1, Member, IEEE, P. Barrade2, Member IEEE, Simulation of a Series Hybrid Electric Vehicle based on Energetic Macroscopic Representation, IL2EP Lille, USTL, 59 655 Villeneuve d'Ascq, France 2 LEI, Ecole Polytechnique Fédérale de Lausanne, Switzerland.
- [8] E. Surewaard, M. Thele, Ford Forschungszentrum Aachen, RWTH Aachen University, Germany, Modelica in Automotive Simulations - Powernet Voltage Control during Engine Idle, pp. 309-318.
- [9] Y.H. Zweiri, J.F. Whidborne, L.D. Seneviratne and K. Althoefer: A Comparison of Dynamic Models of Various

- Complexity for Diesel Engines. *Mathematical and Computer Modelling of Dynamical Systems Journal*, 8(3): 273-289, 2002.
- [10] A. De Bernardenis, F. Meibody-Tabar and B. Laporte, An original battery charger for embarked systems, *8<sup>th</sup> EPE'99 Conference*, CD-Rom Proceedings, 7-9 September 1999, Lausanne, Switzerland.
- [11] Paul Bentley, *The use of Valve Regulated Sealed Lead Acid Batteries in Hybrid Electric Vehicle*, A thesis submitted for the degree of Doctor of Philosophy in the department of Electronic and Electrical Engineering, University of Sheffield. June, 2004.
- [12] Sabine Piller, Marion Perrin, Andreas Josen, Methods for state-of-charge determination and their applications, *Journal of Power Sources* 96 (2001) 113-120.
- [13] Guillaume Dillenseger, *Caractérisation de nouveaux modes de maintien en charge pour batteries stationnaires de secours*, PhD thesis, University of Montpellier II.
- [14] Stefano Barsali and Massimo Ceraolo, Dynamical Models of Lead-Acid Batteries: Implementation Issues, *IEEE TRANSACTIONS ON ENERGY CONVERSION*, VOL. 17, NO. 1, MARCH 2002.
- [15] Massimo Ceraolo, New Dynamical Models of Lead-Acid Batteries, *IEEE Transactions on power systems*, vol.15, No. 4, nov. 2000.
- [16] Ziyad M. Salameh, Margaret A. Casacca William, A. Lynch, A Mathematical Model for Lead-Acid Batteries, Department of Electrical Engineering, University of Lowell, *IEEE*, 1992.
- [17] Michel F. de Koning, André Veltman, modeling battery efficiency with parallel branches, 2004, *35<sup>th</sup> annual IEEE power Electronics Specialists conference*.
- [18] M. Ito, R. Uotome, R. Yamamoto, N. Hoshino, T. Toguchi, M. Tateno, The development of High Voltage DC Power Relay for Electric Vehicle, *Matsushita Electric Works*.
- [19] M. Baleani, A. Ferrari, L. Mangeruca, A. Sangiovanni-Vincentelli, Maurizio Peri, Saverio Pezzini, Fault-Tolerant platforms for automotive safety-critical application, *CASES'03*, Oct. 30-Nov. 2, 2003, San Jose, California USA.
- [20] Mauro Andriollo, Francesco Castelli Dezza, Marco Tamburrino, Converter control strategies for the power flow management in a fuel-cell Supplied vehicle for the public city transportation, *SPEEDAM 2004* June 16th, CAPRI (Italy).

A. Berthon received his Dipl. engineer in electrical engineering from ENSEM in Nancy in 1972 and his Dr. Ing. degree from the University of Franche-Comté. He is currently Professor at IUT and head of power electronics team at the L2ES laboratory. He is working in the field of power electronics converters, drives and electrical power management for electrical and hybrid vehicle.

## Authors' information



**K. El Kadri**, Dipl.-Ing.

She is with the Electrical Engineering and Systems Laboratory L2ES and the University of Technology Belfort-Montbéliard, Bât F, rue Thierry Mieg, F – 90010 BELFORT Cedex (corresponding author to provide phone: (+33) 3 84 58 36 13; fax: (+33) 3 84 58 36 36; e-mail: [khadija.elkadri@utbm.fr](mailto:khadija.elkadri@utbm.fr)).

**K. El Kadri** got the Dipl.-Ing. degree in 1998 from the Ecole Nationale Supérieure d'Electrotechnique, d'Electronique, d'Informatique et d'Hydraulique de Toulouse (**ENSEEIH**T). She is an associate professor at the University of Belfort Montbéliard. His research interest is the hybrid vehicle and the energy sources.



**A. Berthon** Pr.Dr.Ing.

He is with the Electrical Engineering and Systems Laboratory L2ES and the University of Franche Comté, Bât F, rue Thierry Mieg, F – 90010 BELFORT Cedex (corresponding author to provide phone: (+33) 3 84 58 36 04; fax: (+33) 3 84 58 36 36; e-mail: [alain.berthon@univ-fcomte.fr](mailto:alain.berthon@univ-fcomte.fr)).